



HIGH TEMPERATURE HIGH BANDWIDTH AMPLIFIED GAS TURBINE PRESSURE TRANSDUCER

ETL-GTS-X-312 (M) SERIES

- Miniature, Robust Construction
- High Temperature
- Acceleration & Vibration Insensitive
- Patented Leadless Technology VIS®
- High Bandwidth Amplifier
- Separate DC and AC Outputs
- Dynamic and Static Capability



The ETL-GTS Series are high temperature, extremely rugged pressure transducers which are ideal for the measurement of instabilities and steady pressures in gas turbine combustors and compressors. They use a patented acceleration insensitive leadless sensing element that is more than 1000 times less sensitive to vibration than other Kulite transducers. The front of the transducers can withstand temperatures of 932°F (500°C)* while the in-line amplifier can be placed in a cooler area. The amplifier is compatible with both existing and new data acquisition systems with a measurement bandwidth of up to 150KHz, specified by Option *.

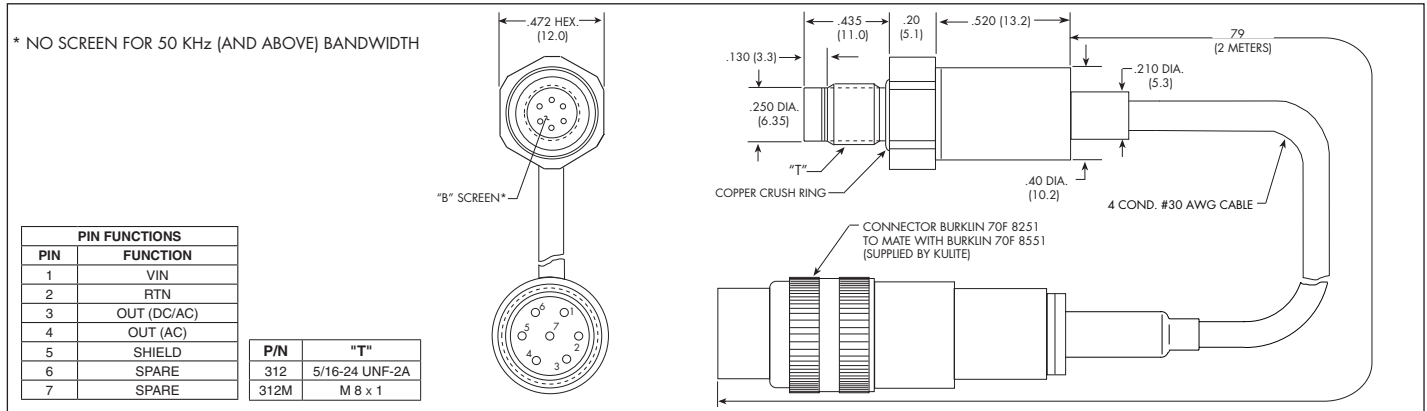

INPUT	Pressure Range	3.5 50	7 100	14 200	21 300	35 500	70 BAR 1000 PSI
	Operational Mode	Absolute, Sealed Gage					
	Over Pressure	2 Times Rated Pressure to 1000 PSI (70 BAR) 1.5 Times Rated Pressure Above 1000 PSI to a Max. of 6000 PSI (415 BAR)					
	Burst Pressure	3 Times Rated Pressure					
	Pressure Media	All Nonconductive, Noncorrosive Liquids or Gases (Most Conductive Liquids and Gases - Please Consult Factory)					
ELECTRICAL PERFORMANCE	Maximum Electrical Current	25 mA					
	Rated Electrical Excitation	12 - 36 VDC					
	Output Range	Output 1: 0.5V to 5V ± 3% (DC/AC)			Output 2: 0.5V to 9.5V ± 3% (AC)		
	Output Impedance	200 Ohms (Typ.)					
	Amplifier Bandwidth (-3dB) Only	Output 1: DC to 5kHz (Option A), 50kHz* (Option B) or 150kHz* (Option C) Output 2: AC 10Hz to 5kHz (Option A), 50kHz* (Option B) or 150kHz* (Option C) (X10 Additional gain)					
	Output Filter	Low Pass Filter Available per Customer Specification					
Residual Unbalance	Output 1: 500mV ± 50mV (DC/AC)			Output 2: 5.0V ± 0.5V (AC)			
OUTPUT	Resolution	Infinitesimal					
	Natural Frequency of Sensor Without Screen (KHz) (Typ.)	Greater Than 300 KHz					
	Insulation Resistance	100 Megohm Min. @ 50 VDC					
ENVIRONMENTAL	Operating Temperature Range	-65°F to +932°F** (-55°C to +500°C) (Front End) -40°F to +185°F (-40°C to +85°C) (Connector and Amplifier) -65°F to 662°F (-55°C to 350°C) (Cable)					
	Compensated Temperature Range	+80°F to +572°F (+25°C to +300°C)					
	Thermal Zero Shift	± 1.5% FS/100°F (Typ.)					
	Thermal Sensitivity Shift	± 1.5% /100°F (Typ.)					
	Linear Vibration	10-2,000 Hz Sine, 100g (Max.)					
Mechanical Shock	20g half Sine Wave 11 msec. Duration						
PHYSICAL	Electrical Connection	Burklin 70F 8251 Connector (Mating Connector Supplied Burklin 70F 8551)					
	Weight	10 Grams (Nom.) Excluding Cable and Connector					
	Pressure Sensing Principle	Fully Active Four Arm Wheatstone Bridge Dielectrically Isolated Silicon on Silicon Patented Leadless Technology					
	Mounting Torque	75 Inch-Pounds (Max.) 8.5 Nm					

** Limited life above 850°F (454°C) dependent on operating conditions.

Note: Custom pressure ranges, accuracies and mechanical configurations available. Dimensions are in inches. Dimensions in parenthesis are in millimeters. All dimensions nominal. (P) Continuous development and refinement of our products may result in specification changes without notice. Copyright © 2014 Kulite Semiconductor Products, Inc. All Rights Reserved.

Kulite miniature pressure transducers are intended for use in test and research and development programs and are not necessarily designed to be used in production applications. For products designed to be used in production programs, please consult the factory.